

Two-part-weld-construction with plastic pads

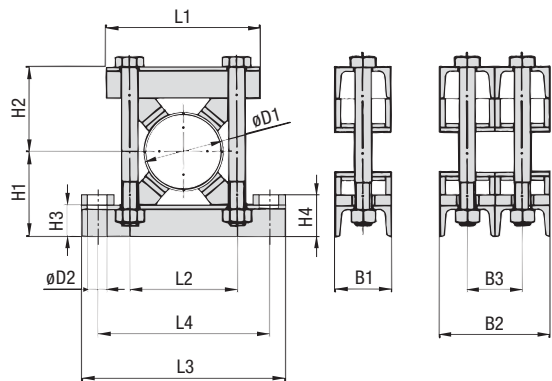
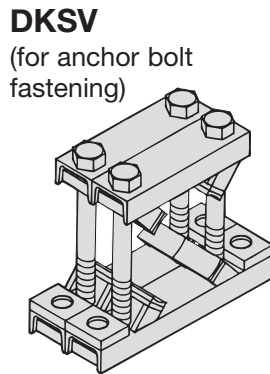
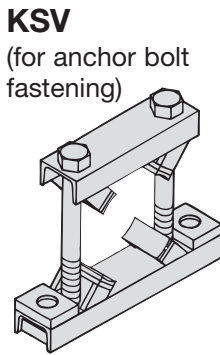
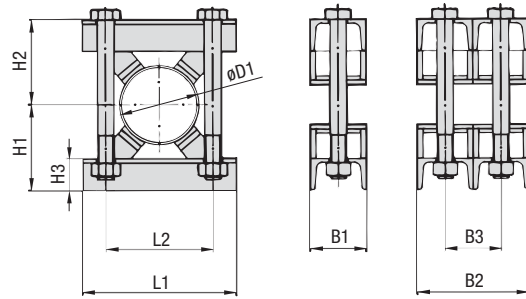
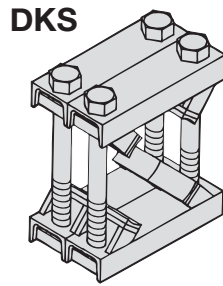
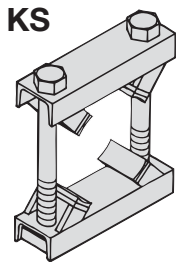

Pipe-O.D. Ø D1 mm in	L1	L2	L3	L4	H1	H2	H3	H4	B1	B2	B3	D2	Hexagon Head Bolt	Number of plastic pads
220 to 275 8.66" to 10.85"	420 16.54"	330 12.99"	580 22.83"	490 19.29"	220 8.66"	220 8.66"	60 2.36"	90 3.54"	140 5.51"	290 11.41"	150 5.91"	35 1.38"	M30 x 420	4
276 to 325 10.87" to 12.80"	460 18.11"	370 14.57"	620 24.41"	530 20.87"	240 9.45"	240 9.45"	60 2.36"	90 3.54"	140 5.51"	290 11.41"	150 5.91"	35 1.38"	M30 x 460	4
326 to 370 12.83" to 14.57"	510 20.08"	420 16.53"	670 26.38"	580 22.83"	260 10.23"	260 10.23"	60 2.36"	90 3.54"	140 5.51"	290 11.41"	150 5.91"	35 1.38"	M30 x 500	4
371 to 425 14.61" to 16.73"	570 22.44"	480 18.89"	750 29.53"	640 25.20"	290 11.42"	290 11.42"	60 2.36"	90 3.54"	140 5.51"	290 11.41"	150 5.91"	35 1.38"	M30 x 560	4
426 to 485 16.77" to 19.09"	620 24.41"	530 20.87"	800 31.50"	730 28.74"	305 12.01"	305 12.01"	60 2.36"	90 3.54"	140 5.51"	290 11.41"	150 5.91"	35 1.38"	M30 x 590	4
486 to 550 19.13" to 21.65"	680 26.77"	590 23.23"	860 33.86"	790 31.10"	370 14.57"	370 14.57"	60 2.36"	90 3.54"	140 5.51"	290 11.41"	150 5.91"	35 1.38"	M30 x 720	4
551 to 630 21.69" to 24.80"	760 29.92"	670 26.38"	940 37.00"	870 34.25"	410 16.14"	410 16.14"	60 2.36"	90 3.54"	140 5.51"	290 11.41"	150 5.91"	35 1.38"	M30 x 800	5
631 to 715 24.84" to 28.15"	845 33.27"	755 29.72"	1025 40.35"	955 37.60"	452 17.80"	452 17.80"	60 2.36"	90 3.54"	140 5.51"	290 11.41"	150 5.91"	35 1.38"	M30 x 884	5
716 to 800 28.19" to 31.50"	940 37.00"	850 33.46"	1120 44.09"	1050 41.34"	495 19.49"	495 19.49"	60 2.36"	90 3.54"	140 5.51"	290 11.41"	150 5.91"	35 1.38"	M30 x 970	5

## ORDER CODES

**KSx \*\*\*\* xx xx**

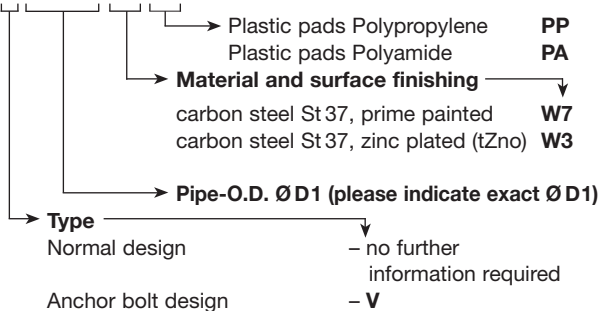

**DKSx \*\*\*\* xx xx**

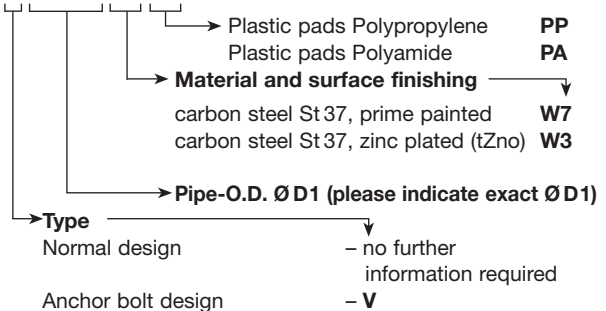

Other materials, surface finishings and diameters upon request.